



# MATCH-UP

Contemporary design

# FLORIM È CERTIFICATA B CORP

FLORIM IS  
B CORP  
CERTIFIED

Guardiamo al business come una forza positiva in grado di generare profitto e allo stesso tempo creare un impatto virtuoso sulle persone e sull'ambiente. Da sempre.

Le nostre scelte, giorno dopo giorno, ci hanno portato a migliorare il nostro modo di fare impresa.

*We conceive the business as a positive force able to generate profits and at the same time create a virtuous impact on people and the environment. Since forever.*

*Our choices, day after day, have led us to improve our way of doing business.*

## COSA SIGNIFICA ESSERE B CORP?

Ci siamo misurati con i **più alti standard di performance sociale e ambientale** e dopo un lungo e rigoroso processo di verifica **siamo diventati B Corp.**

Le aziende che riescono a ottenere questa certificazione sono le più evolute al mondo in termini di impatto positivo sia sociale che ambientale.

Costituiscono un movimento globale di 'Purpose Driven Businesses' che ha l'obiettivo di diffondere un nuovo **paradigma economico**, che vede le imprese come protagoniste nel **rigenerare la società.**



Certified



Corporation



Guarda il video *"Essere sostenibile è una scelta quotidiana"* con i volti di alcune delle "persone Florim" che ogni giorno contribuiscono a rendere l'azienda sempre più responsabile.  
*Watch the video "Being sustainable is a daily choice" with the faces of some of the "Florim people" who contribute to making the company even more responsible, every day.*

## WHAT DOES IT MEAN TO BE B CORP?

We vied with the **highest social and environmental performance standards**, and after a long and scrupulous verification process, **we became B Corp.**

Companies that succeed in obtaining this certification are the most evolved in the world in terms of their positive social and environmental impact.

They constitute a global movement of 'Purpose Driven Businesses' whose aim is to diffuse a **new economic paradigm**, whereby companies are the drivers of **social regeneration.**

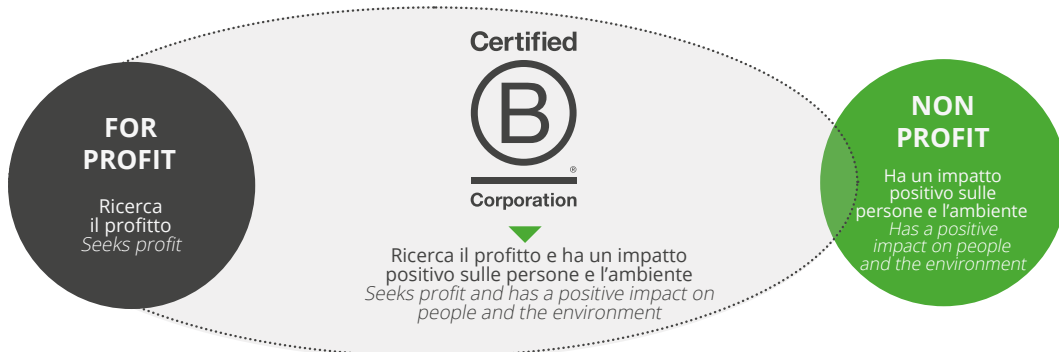

## BUSINESS RIGENERATIVO

È in corso un **cambiamento culturale** epocale di cui siamo orgogliosi di essere parte. Uno dei principi fondamentali di tutte le B Corp è quello di adottare un business rigenerativo che si contrappone a quello estrattivo.

Rigenerare significa non solo diminuire l'impatto sulla natura e sull'ambiente che ci circonda, ma addirittura produrre effetti positivi, creando valore condiviso nella società e rigenerando la biosfera.

Diventano B Corp solo quelle aziende che misurano il loro impatto complessivo attraverso il Benefit Impact Assessment (BIA) superando il punteggio di 80 (in una scala da 0 a 200) ed entrando così in una élite di imprese **rigenerative**. Chi non supera questa soglia viene considerata **azienda estrattiva** ovvero per funzionare consuma risorse economiche, sociali e ambientali superiori di quanto sia in grado di generare come output.

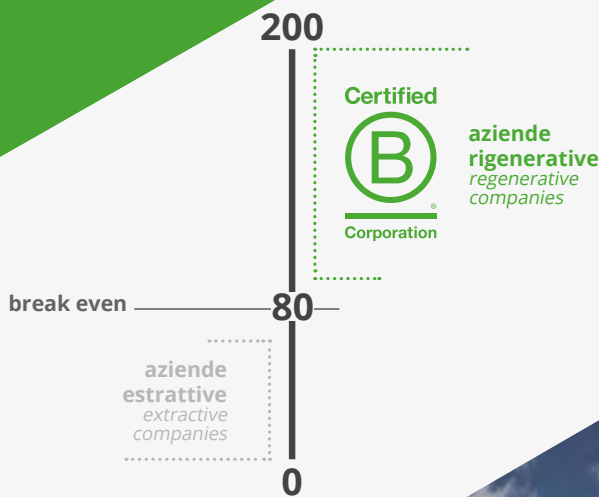

## REGENERATIVE BUSINESS

An historical **cultural shift** is under way, of which we are proud to be a part. One of the underlying principles of all B Corps is the adoption of a regenerative business model as opposed to an extractive one.

Regenerating means not only reducing the impact of business on our surrounding nature and environment, but also producing **positive effects, creating shared value in society and regenerating the biosphere**.

Only those companies that measure their overall impact through the Benefit Impact Assessment (BIA) exceeding the score of 80 points can be certified as B Corp, joining an elite of **regenerative companies**. Anyone who does not exceed this threshold is considered an **extractive company** or, in order to function, they consume higher economic, social and environmental resources than they are able to generate as output.

## IL PUNTEGGIO DI FLORIM

Il punteggio conseguito da Florim Italia è di 98,1 punti e il consolidato, che comprende la consociata americana, è di 90,9 punti. Così Florim rientra tra le migliori B Corp al mondo.

Sono oltre 140.000 le aziende che stanno cercando di ottenere la certificazione, nel rispetto di **severissimi standard di trasparenza e sostenibilità**.

Solo il 3% riesce a superare l'iter di verifica imposto da **B Lab**, ente certificatore di origine americana che oggi opera a livello globale.

## FLORIM'S SCORE

Florim Italia score is 98.1 points and the consolidated, which includes the American subsidiary, is 90.9 points. Florim is now one of the best B Corps throughout the world.

More than 140,000 companies are currently seeking to obtain the certification **in compliance with the strictest transparency and sustainability standards**.

Only 3% manage to pass the verification process implemented by **B Lab**, the US certifying body that currently operates on a global scale.

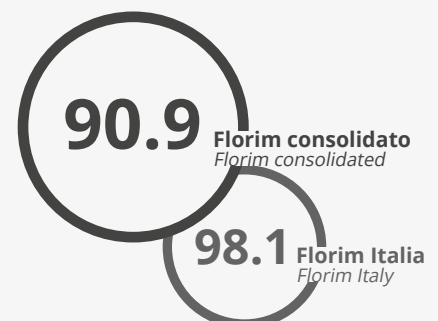

# Contemporary design

Materiale versatile, dinamico, fresco adatto per vestire ogni ambiente domestico secondo il proprio stile e la propria personalità. Le differenti superfici sono la giusta risposta anche per le applicazioni commerciali a medio e basso traffico.

A versatile, dynamic, new material suitable for clothing any domestic environment according to one's own style and personality. The different surfaces are the perfect solution even for commercial applications with medium to low footfall.

Matériau polyvalent, dynamique et actuel, idéal pour le revêtement de tout environnement domestique en s'adaptant au style et à la personnalité de chacun. Les différentes surfaces offrent également une solution idéale pour les applications commerciales à trafic moyen et faible.

Vielseitig einsetzbares, dynamisches, frisch wirkendes Material, das sich auf den individuellen Stil und die Persönlichkeit eines jeden Wohnambiente abstimmen lässt. Die verschiedenen Flächenbeläge sind auch für wenig bis mittelhoch frequentierte gewerbliche Bereiche die ideale Lösung.

Material versátil, dinámico y fresco, ideal para vestir cualquier ambiente doméstico con su propio estilo y personalidad. Las diferentes superficies son la respuesta perfecta también para aplicaciones comerciales de mediano y bajo tránsito.

versatility



fresh



ness



functionality



simplicity

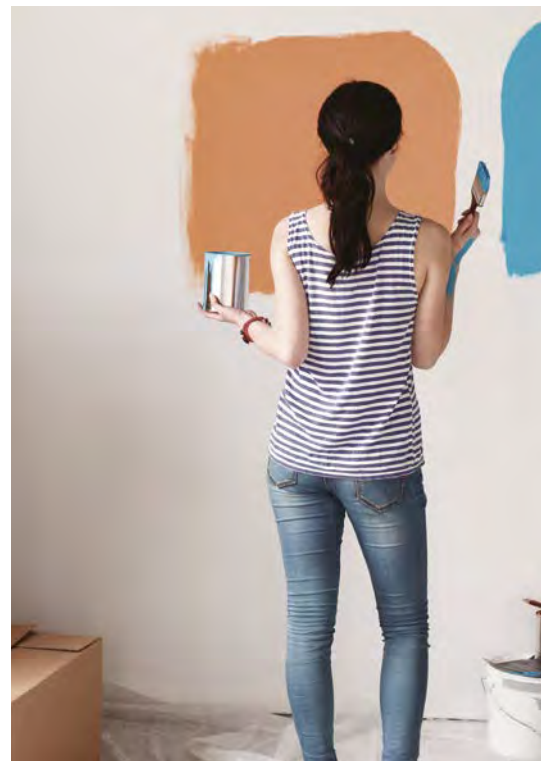

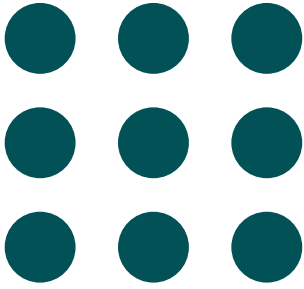

# MATCH-UP



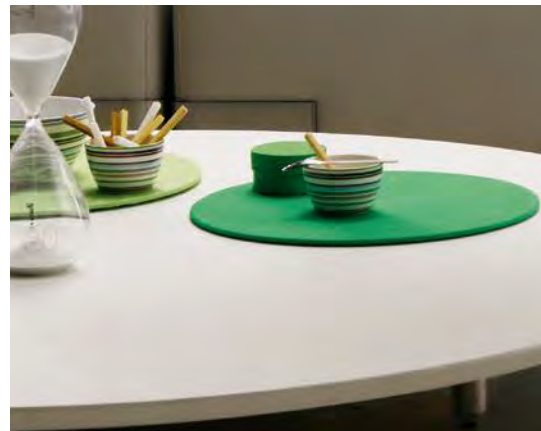

**Contemporary design**



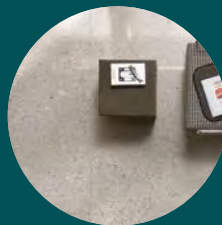

# MATCH-UP





Dall'incontro tra due materie diverse nasce un progetto contemporaneo e di tendenza che mescola insieme superfici, colori e linguaggi per proporre accostamenti originali. **Match-Up** è un gioco di contrasti che attraverso un patchwork materico si presta ad un equilibrato mix and match di stili e colorazioni. Sono due le superfici di partenza con cui creare molteplici accostamenti: un effetto cemento, dall'estetica urbana e industriale, e un originale effetto graniglia che amalgama insieme elementi materici tono su tono di forme irregolari e dimensioni variabili. In **Match-Up** tonalità neutre si sommano con gli accenni cromatici del giallo senape e dell'azzurro, suggerendo piacevoli abbinamenti tra le tinte calde di Cookie, Coffee, Cinnamon e quelle fredde di Earl Grey, Liquorice, Blueberry. Il colore Sugar, facilmente coordinabile a tutti gli altri, diventa l'elemento trasversale capace di assumere significati diversi a seconda del contesto in cui viene inserito.



# MATCH-UP

The union of two different materials has resulted in a contemporary, trendy project that mixes surfaces, colours and languages to offer original combinations. **Match-Up** features an interplay of different contrasts through tactile patchwork suited to a balanced mix and match of styles and colours. There are two basic surfaces that can be used to create multiple combinations: a concrete effect with an urban and industrial aesthetic and an original marble agglomerate effect that blends tone-on-tone tactile elements with irregular shapes and varying sizes. In **Match-Up** neutral shades are combined with chromatic hints of mustard yellow and light blue, offering pleasant combinations of the warm shades of Cookie, Coffee and Cinnamon, as well as colder tones of Earl Grey, Liquorice and Blueberry. The Sugar colour, which can be easily coordinated with all the others, becomes the collection's most versatile element that can take on different meanings depending on the context in which it is inserted.

Contemporain et tendance, mélangeant surfaces, couleurs et langages pour donner lieu à des associations originales: tel est le projet né de la rencontre entre deux matières différentes. **Match-Up** est un jeu de contrastes qui à travers un patchwork de matières se prêtant à un mix and match équilibré de styles et de couleurs. Deux surfaces de base permettent de créer une multitude d'associations: un effet béton à l'esthétique urbaine et industrielle et un effet grenaille original qui amalgame des éléments de matière ton sur ton, de forme irrégulière et de taille variable. Dans **Match-Up**, les tonalités neutres et contemporaines s'associent aux accents de couleurs du jaune moutarde et du bleu clair, suggérant d'agréables combinaisons entre les teintes chaudes de Cookie, Coffee, Cinnamon et celles froides de Earl Grey, Liquorice, Blueberry. La couleur Sugar, qui se coordonne facilement avec toutes les autres, devient l'élément le plus polyvalent, prenant des significations différentes en fonction du contexte où elle s'inscrit.



Aus dem Spannungsfeld von zwei unterschiedlichen Materialien geht ein zeitgemäßes, trendiges Konzept hervor, das durch einen Mix aus Oberflächen, Farben und Ausdrucksformen originelle Kombinationen bietet. **Match-Up** ist ein Spiel der Kontraste. Es lockert die Schlichtheit minimalistischer Interieurs durch ein Patchwork aus Materialoptiken in einem ausgewogenen Mix and Match aus Stilthemen und Farben auf. Aus zwei Ausgangsoberflächen lassen sich vielfältige Kombinationen, die Mode- und Lifestyle-Trends aufgreifen, realisieren: eine Betonoptik für einen urbanen Industrie-Look und eine originelle Ceppo di Grè-Optik, bei der Ton in Ton Materialfragmente mit unregelmäßiger Form und unterschiedlicher Größe harmonisch zusammengefügt sind. In der Kollektion **Match-Up** fügen sich moderne, neutrale Farben zu senfgelben und himmelblauen Nuancen. Die Kollektion inspiriert zu ansprechenden Kombinationen zwischen den warmen Farbtönen Cookie, Coffee, Cinnamon und den kalten Nuancen Earl Grey, Liquorice und Blueberry. Außerdem wird die Farbe Sugar, die sich leicht mit allen anderen kombinieren lässt, zum wiederkehrenden Universalelement der Kollektion, das je nach Einsatzumfeld unterschiedlich stark zum Ausdruck kommt.

apri  
Ton  
Ga

A partir de la suma de dos materias distintas nace un proyecto contemporáneo y de moda que mezcla superficies, colores y lenguajes para proponer combinaciones originales. **Match-Up** brinda un juego de contrastes por medio de un patchwork matérico que se presta a un equilibrado mix and match de estilos y coloraciones. Dos son las superficies de partida con las que crear múltiples combinaciones: un efecto cemento, de estética urbana e industrial, y un original efecto arenilla que amalgama conjuntamente elementos matéricos tono sobre tono de formas irregulares y medidas variables. En **Match-Up** los tonos neutros se suman a los matices cromáticos del amarillo mostaza y del azul, sugiriendo agradables combinaciones entre los colores cálidos de Cookie, Coffee, Cinnamon y los fríos de Earl Grey, Liquorice, Blueberry. La tonalidad Sugar, fácilmente coordinable con todas las demás, se convierte en el elemento transversal y más versátil de la colección, capaz de adquirir significados diferentes según el contexto en que se introduzca.

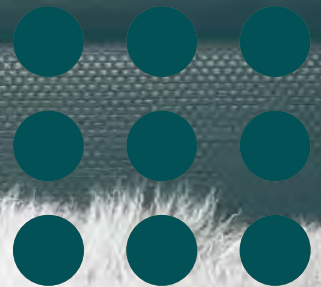





wall: blueberry comfort 60x120 23<sup>5/8</sup>"x47<sup>1/4</sup>" sugar comfort 120x280 47<sup>1/4</sup>"x110<sup>1/4</sup>"  
floor: liquorice mix comfort 60x60 23<sup>3/8</sup>"x23<sup>5/8</sup>"



**wall:** blueberry comfort 60x120 23<sup>5/8</sup>"x47<sup>1/4</sup>" **sugar mix** comfort 120x280 47<sup>1/4</sup>"x110<sup>1/4</sup>"  
**floor:** sugar mix comfort 60x120 23<sup>5/8</sup>"x47<sup>1/4</sup>"





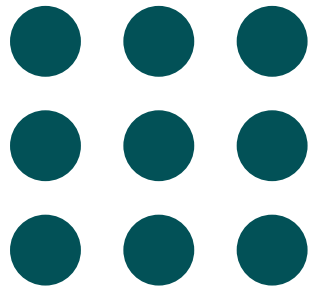



wall: decoro waves matte 120x280 47<sup>1/4</sup>"x110<sup>1/4</sup>"  
floor: cookie comfort 60x60 23<sup>5/8</sup>"x23<sup>5/8</sup>"





wall: earl grey mix glossy 120x280 47<sup>1</sup>/<sub>4</sub>"x110<sup>1</sup>/<sub>4</sub>"  
floor: decoro shapes comfort





wall: earl grey mix glossy 120x280 47 1/4"x110 1/4"  
floor: decoro shapes comfort





floor: decoro shapes comfort





wall: decoro tropico matte 120x280 47<sup>1/4</sup>"x110<sup>1/4</sup>"  
floor: coffee comfort 60x120 23<sup>3/4</sup>"x47<sup>1/4</sup>"





wall: **decore tropico** matte 120x280 47<sup>1/4</sup>"x110<sup>1/4</sup>"  
floor: **coffee comfort** 60x120 23<sup>5/8</sup>"x47<sup>1/4</sup>"



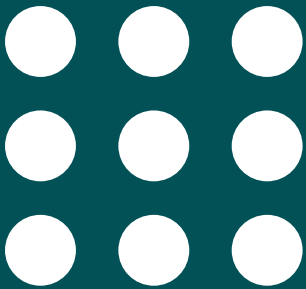





wall: blueberry comfort 60x120 23<sup>5</sup>/<sub>8</sub>"x47<sup>1</sup>/<sub>4</sub>" decoro zig zag comfort  
floor: earl grey mix comfort 60x120 23<sup>5</sup>/<sub>8</sub>"x47<sup>1</sup>/<sub>4</sub>" blueberry comfort 60x120 23<sup>5</sup>/<sub>8</sub>"x47<sup>1</sup>/<sub>4</sub>"





wall: blueberry comfort 60x120 23<sup>5</sup>/<sub>8</sub>"x47<sup>1</sup>/<sub>4</sub>" decoro zig zag comfort  
floor: earl grey mix comfort 60x120 23<sup>5</sup>/<sub>8</sub>"x47<sup>1</sup>/<sub>4</sub>" blueberry comfort 60x120 23<sup>5</sup>/<sub>8</sub>"x47<sup>1</sup>/<sub>4</sub>"





wall: decoro waves matte 120x280 47<sup>1/4"</sup> x110<sup>1/4"</sup>  
floor: coffee mix comfort 60x120-23<sup>5/8"</sup> x47<sup>1/4"</sup>





wall: decoro waves matte 120x280 471<sup>cm</sup> x 110<sup>1/2m</sup>  
floor: coffee mix comfort 60x120 23<sup>5/8m</sup> x 47<sup>1/4m</sup>







wall: **deco waves** matte 120x280 47<sup>1/4"</sup>x110<sup>1/4"</sup> / 60x120 23<sup>5/8"</sup>x47<sup>1/4"</sup> **cinnamon** comfort 60x120 23<sup>5/8"</sup>x47<sup>1/4"</sup>  
floor: **coffee** comfort 60x60 23<sup>5/8"</sup>x23<sup>5/8"</sup>



wall: decoro waves matte 120x280 47<sup>1/4</sup>"x110<sup>1/4</sup>" / 60x120 23<sup>5/8</sup>"x47<sup>1/4</sup>" cinnamon comfort 60x120 23<sup>5/8</sup>"x47<sup>1/4</sup>"

floor: coffee comfort 60x60 23<sup>5/8</sup>"x23<sup>5/8</sup>"



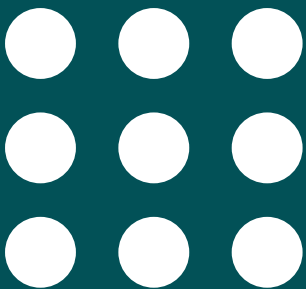





fireplace: liquorice comfort 60x120 23<sup>5/8</sup>"x47<sup>1/4</sup>"  
floor: earl grey mix glossy 120x120 47<sup>1/4</sup>"x47<sup>1/4</sup>"





floor: earl grey mix glossy 120x120 47<sup>1/4</sup>"x47<sup>1/4</sup>"

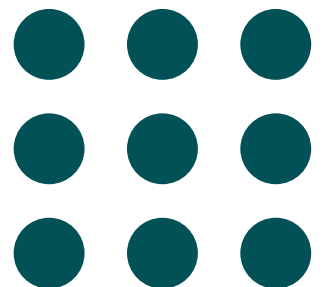



**fireplace:** liquorice comfort 60x120 23<sup>5/8"</sup>x47<sup>1/4"</sup>  
**floor:** earl grey mix glossy 120x120 47<sup>1/4"</sup>x47<sup>1/4"</sup>



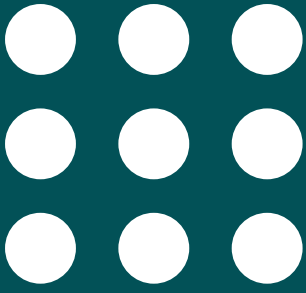

wall: cookie comfort 120x240 47<sup>1/4</sup>"x94<sup>1/2</sup>"  
floor: cookie mix glossy 120x120 47<sup>1/4</sup>"x47<sup>1/4</sup>"

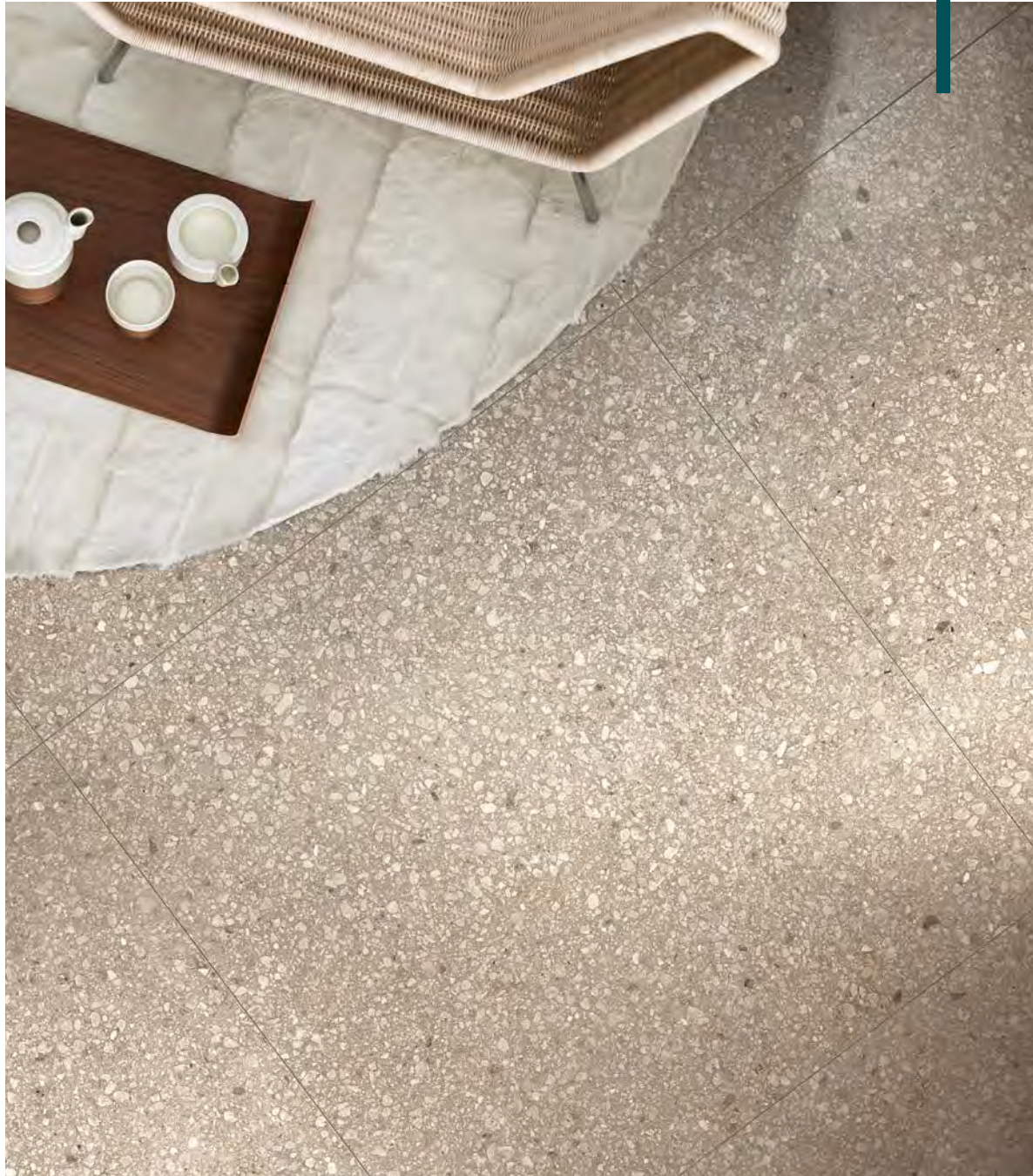







wall: **decoro lock** comfort  
floor: **liquorice** comfort 60x120 23<sup>5</sup>/<sub>8</sub>"x47<sup>1</sup>/<sub>4</sub>"





wall: **decoro tropico** matte 120x280 47<sup>1/4</sup>"x110<sup>1/4</sup>"  
floor: **earl grey** comfort 60x120 23<sup>5/8</sup>"x47<sup>1/4</sup>"

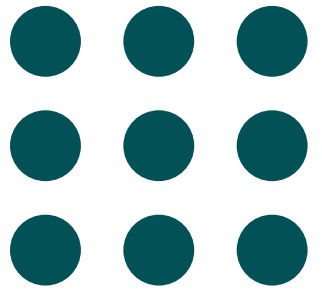



wall: decoro tropico matte 120x280 47<sup>1/4</sup>"x110<sup>1/4</sup>"  
floor: earl grey comfort 60x120 23<sup>5/8</sup>"x47<sup>1/4</sup>"





wall: decoro tropico matte 120x280 47<sup>1</sup>/<sub>4</sub>"x110<sup>1</sup>/<sub>4</sub>"  
floor: earl grey comfort 60x120 23<sup>5</sup>/<sub>8</sub>"x47<sup>1</sup>/<sub>4</sub>"



www.kristin.com

SUITED & BOOED



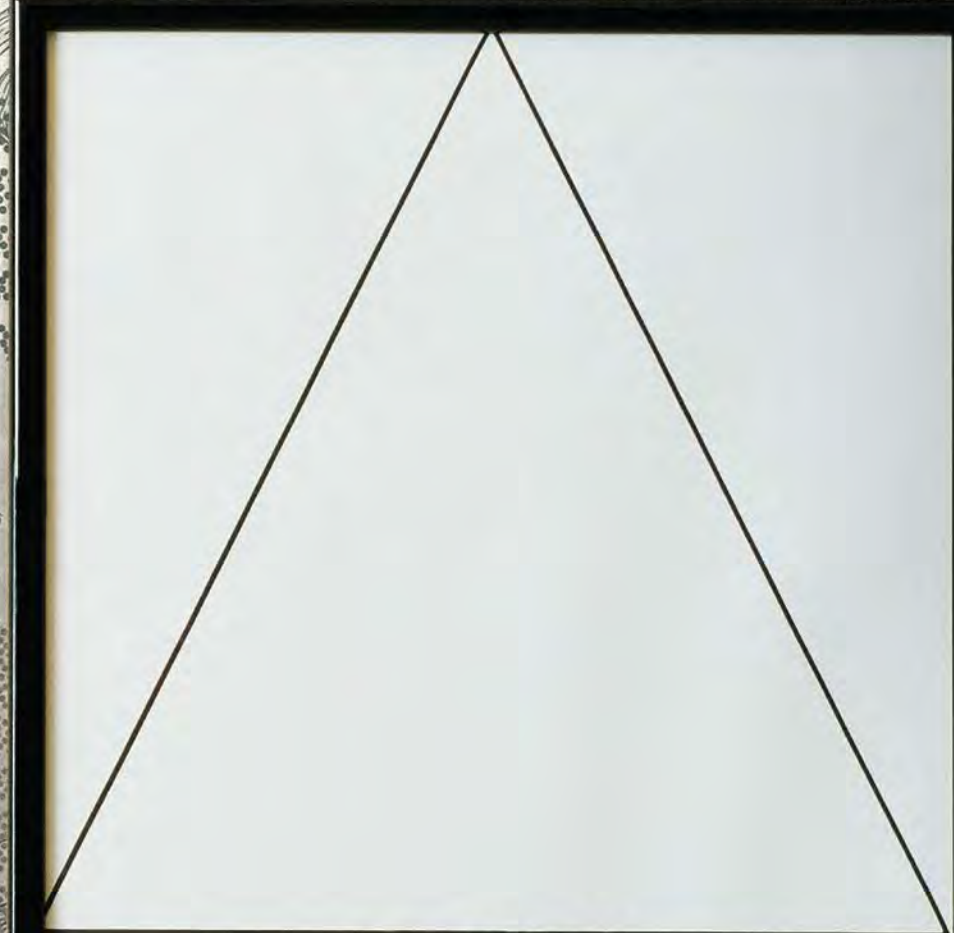



Museo speri  
contemporan  
  
aprile - settem  
Torino  
Galleria civic





**SUGAR**

**GRES FINE PORCELLANATO**

FINE PORCELAIN STONEWARE / GRÈS CÉRAMÉ FIN / FEINSTEINZEUG-KOLLEKTIONEN / GRES PORCELÁNICO FINO  
 SQUADRATO - SQUARED - EQUARRI - REKTIFIZIERT - ESCUADRADO

9 mm 3/8" 	COLOR	SURFACE	60x120 23 <sup>5/8"</sup> x47 <sup>1/4"</sup>	60x60 23 <sup>5/8"</sup> x23 <sup>5/8"</sup>	30x60 11 <sup>4/5"</sup> x23 <sup>5/8"</sup>
<b>MATCH-UP</b> 	SUGAR	COMFORT	772185	772235	772223
		GRIP	772186	-	-

6 mm 1/4" 	<small>FLOHM OVERSIZE</small> <b>magnUm</b>	COLOR	SURFACE	120x280 47 <sup>11/16"</sup> x110 <sup>1/4"</sup>	120x240 47 <sup>1/4"</sup> x94 <sup>1/2"</sup>	120x120 47 <sup>1/4"</sup> x47 <sup>1/4"</sup>	60x120 23 <sup>5/8"</sup> x47 <sup>1/4"</sup>
<b>MATCH-UP</b> 	SUGAR	COMFORT		772304	772301	772302	772303

# MATCH-UP



## SUGAR MIX

**GRES FINE PORCELLANATO**  
 FINE PORCELAIN STONEWARE / GRÈS CÉRAMÉ FIN / FEINSTEINZEUG-KOLLEKTIONEN / GRES PORCELÁNICO FINO  
 SQUADRATO - SQUARED - EQUARRI - REKTIFIZIERT - ESCUADRADO

9 mm 3/8" ↑↓	COLOR	SURFACE	60x120	60x60	30x60
			23 <sup>5/8"</sup> x47 <sup>1/4"</sup>	23 <sup>5/8"</sup> x23 <sup>5/8"</sup>	11 <sup>4/5"</sup> x23 <sup>5/8"</sup>
	SUGAR MIX	COMFORT	772199	772242	772230
		GRIP	772200	-	-



6 mm 1/4" ↑↓	FLORIN OVERSIZE magnUm	COLOR	SURFACE	120x280	120x240	120x120	60x120
				47 <sup>1/4"</sup> x110 <sup>1/4"</sup>	47 <sup>1/4"</sup> x94 <sup>1/2"</sup>	47 <sup>1/4"</sup> x47 <sup>1/4"</sup>	23 <sup>5/8"</sup> x47 <sup>1/4"</sup>
<b>MATCH-UP</b>		SUGAR MIX	COMFORT	772311	772318	772325	772332
			GLOSSY	772305	772306	772307	772308





COOKIE

**GRES FINE PORCELLANATO**

FINE PORCELAIN STONEWARE / GRÈS CÉRAMÉ FIN / FEINSTEINZEUG-KOLLEKTIONEN / GRES PORCELÁNICO FINO  
 SQUADRATO - SQUARED - EQUARRI - REKTIFIZIERT - ESCUADRADO

9 mm 3/8" 	COLOR	SURFACE	60x120 23 <sup>5/8"</sup> x47 <sup>1/4"</sup>	60x60 23 <sup>5/8"</sup> x23 <sup>5/8"</sup>	30x60 11 <sup>4/5"</sup> x23 <sup>5/8"</sup>
<b>MATCH-UP</b> 	COOKIE	COMFORT	772187	772236	772224
		GRIP	772188	-	-

6 mm 1/4" 	<small>FLOHM OVERSIZE</small> <b>magnUm</b>	COLOR	SURFACE	120x280 47 <sup>11/16"</sup> x110 <sup>1/4"</sup>	120x240 47 <sup>1/4"</sup> x94 <sup>1/2"</sup>	120x120 47 <sup>1/4"</sup> x47 <sup>1/4"</sup>	60x120 23 <sup>3/8"</sup> x47 <sup>1/4"</sup>
<b>MATCH-UP</b> 	COOKIE	COMFORT		772309	772316	772323	772330



COOKIE MIX

**GRES FINE PORCELLANATO**  
 FINE PORCELAIN STONEWARE / GRÈS CÉRAMÉ FIN / FEINSTEINZEUG-KOLLEKTIONEN / GRES PORCELÁNICO FINO  
 SQUADRATO - SQUARED - EQUARRI - REKTIFIZIERT - ESCUADRADO

9 mm 3/8" ↑↓	COLOR	SURFACE	60x120	60x60	30x60
			23 <sup>5/8"</sup> x47 <sup>1/4"</sup>	23 <sup>5/8"</sup> x23 <sup>5/8"</sup>	11 <sup>4/5"</sup> x23 <sup>5/8"</sup>
<b>MATCH-UP</b>	 COOKIE MIX	COMFORT	772201	772243	772231
		GRIP	772202	-	-



6 mm 1/4" ↑↓	FLORIM OVERSIZE <b>magnUm</b>	COLOR	SURFACE	120x280	120x240	120x120	60x120
				47 <sup>11/16"</sup> x110 <sup>1/4"</sup>	47 <sup>1/4"</sup> x94 <sup>1/2"</sup>	47 <sup>1/4"</sup> x47 <sup>1/4"</sup>	23 <sup>3/8"</sup> x47 <sup>1/4"</sup>
<b>MATCH-UP</b>	 COOKIE MIX	COMFORT	772312	772319	772326	772333	
		GLOSSY	772314	772321	772328	772341	





# EARL GREY

## GRES FINE PORCELLANATO

FINE PORCELAIN STONEWARE / GRÈS CÉRAMÉ FIN / FEINSTEINZEUG-KOLLEKTIONEN / GRES PORCELÁNICO FINO  
 SQUADRATO - SQUARED - EQUARRI - REKTIFIZIERT - ESCUADRADO



9 mm 3/8" 	COLOR	SURFACE	60x120 23 <sup>5/8"</sup> x47 <sup>1/4"</sup>	60x60 23 <sup>5/8"</sup> x23 <sup>5/8"</sup>	30x60 11 <sup>4/5"</sup> x23 <sup>5/8"</sup>
<b>MATCH-UP</b> 	EARL GREY	COMFORT	772191	772238	772226
		GRIP	772192	-	-



6 mm 1/4" 	FLOHM OVERSIZE <b>magnUm</b>	COLOR	SURFACE	120x280 47 <sup>1/4"</sup> x110 <sup>1/4"</sup>	120x240 47 <sup>1/4"</sup> x94 <sup>1/2"</sup>	120x120 47 <sup>1/4"</sup> x47 <sup>1/4"</sup>	60x120 23 <sup>5/8"</sup> x47 <sup>1/4"</sup>
<b>MATCH-UP</b> 	EARL GREY	COMFORT	772310	772317	772324	772331	



## EARL GREY MIX

**GRES FINE PORCELLANATO**  
 FINE PORCELAIN STONEWARE / GRÈS CÉRAME FIN / FEINSTEINZEUG-KOLLEKTIONEN / GRES PORCELÁNICO FINO  
 SQUADRATO - SQUARED - EQUARRI - REKTIFIZIERT - ESCUADRADO

9 mm 3/8" 	COLOR	SURFACE	60x120 23 <sup>5/8"</sup> x47 <sup>1/4"</sup>	60x60 23 <sup>5/8"</sup> x23 <sup>5/8"</sup>	30x60 11 <sup>4/5"</sup> x23 <sup>5/8"</sup>
<b>MATCH-UP</b> 	EARL GREY MIX	COMFORT	772205	772245	772233
		GRIP	772206	-	-

6 mm 1/4" 	<small>FLOHM OVERSIZE</small> <b>magnUm</b>	COLOR	SURFACE	120x280 47 <sup>1/4"</sup> x110 <sup>1/4"</sup>	120x240 47 <sup>1/4"</sup> x94 <sup>1/2"</sup>	120x120 47 <sup>1/4"</sup> x47 <sup>1/4"</sup>	60x120 23 <sup>5/8"</sup> x47 <sup>1/4"</sup>
<b>MATCH-UP</b> 	EARL GREY MIX	COMFORT		772313	772320	772327	772340
		GLOSSY		772315	772322	772329	772342



**COFFEE**

**GRES FINE PORCELLANATO**

FINE PORCELAIN STONEWARE / GRÈS CÉRAMÉ FIN / FEINSTEINZEUG-KOLLEKTIONEN / GRES PORCELÁNICO FINO  
 SQUADRATO - SQUARED - EQUARRI - REKTIFIZIERT - ESCUADRADO



9 mm 3/8" ↑↓	COLOR	SURFACE	60x120	60x60	30x60
			23 <sup>5/8"</sup> x47 <sup>1/4"</sup>	23 <sup>5/8"</sup> x23 <sup>5/8"</sup>	11 <sup>4/5"</sup> x23 <sup>5/8"</sup>
<b>MATCH-UP</b>	COFFEE	COMFORT	772189	772237	772225
		GRIP	772190	-	-



**COFFEE MIX**

**MATCH-UP**



**GRES FINE PORCELLANATO**  
 FINE PORCELAIN STONEWARE / GRÈS CÉRAMÉ FIN / FEINSTEINZEUG-KOLLEKTIONEN / GRES PORCELÁNICO FINO  
 SQUADRATO - SQUARED - EQUARRI - REKTIFIZIERT - ESCUADRADO

9 mm 3/8" 	COLOR	SURFACE	60x120	60x60	30x60
			23 <sup>5/8"</sup> x47 <sup>1/4"</sup>	23 <sup>5/8"</sup> x23 <sup>5/8"</sup>	11 <sup>4/5"</sup> x23 <sup>5/8"</sup>
<b>MATCH-UP</b>	 COFFEE MIX	COMFORT	772203	772244	772232
		GRIP	772204	-	-

# LIQUORICE

## GRES FINE PORCELLANATO

FINE PORCELAIN STONEWARE / GRÈS CÉRAMÉ FIN / FEINSTEINZEUG-KOLLEKTIONEN / GRES PORCELÁNICO FINO  
 SQUADRATO - SQUARED - EQUARRI - REKTIFIZIERT - ESCUADRADO



9 mm $\frac{3}{8}$ " 	COLOR	SURFACE	60x120 $23\frac{5}{8}$ "x47 $\frac{1}{4}$ "	60x60 $23\frac{5}{8}$ "x23 $\frac{5}{8}$ "	30x60 $11\frac{4}{5}$ "x23 $\frac{5}{8}$ "
<b>MATCH-UP</b> 	LIQUORICE	COMFORT	772193	772239	772227
		GRIP	772194	-	-



# LIQUORICE MIX

# MATCH-UP

**GRES FINE PORCELLANATO**  
 FINE PORCELAIN STONEWARE / GRÈS CÉRAMÉ FIN / FEINSTEINZEUG-KOLLEKTIONEN / GRES PORCELÁNICO FINO  
 SQUADRATO - SQUARED - EQUARRI - REKTIFIZIERT - ESCUADRADO

9 mm 3/8" 	COLOR	SURFACE	60x120	60x60	30x60
			23 <sup>5/8"</sup> x47 <sup>1/4"</sup>	23 <sup>5/8"</sup> x23 <sup>5/8"</sup>	11 <sup>4/5"</sup> x23 <sup>5/8"</sup>
<b>MATCH-UP</b> 	LIQUORICE MIX	COMFORT	772207	772246	772234
		GRIP	772208	-	-



**BLUEBERRY**

**GRES FINE PORCELLANATO**

FINE PORCELAIN STONEWARE / GRÈS CÉRAMÉ FIN / FEINSTEINZEUG-KOLLEKTIONEN / GRES PORCELÁNICO FINO  
 SQUADRATO - SQUARED - EQUARRI - REKTIFIZIERT - ESCUADRADO



9 mm 3/8" ↑↓	COLOR	SURFACE	60x120	60x60	30x60
			23 <sup>5/8"</sup> x47 <sup>1/4"</sup>	23 <sup>5/8"</sup> x23 <sup>5/8"</sup>	11 <sup>4/5"</sup> x23 <sup>5/8"</sup>
<b>MATCH-UP</b>	 BLUEBERRY	COMFORT	772197	772241	772229
		GRIP	772198	-	-

# MATCH-UP

## CINNAMON

### GRES FINE PORCELLANATO

FINE PORCELAIN STONEWARE / GRÈS CÉRAMÉ FIN / FEINSTEINZEUG-KOLLEKTIONEN / GRES PORCELÁNICO FINO  
SQUADRATO - SQUARED - EQUARRI - REKTIFIZIERT - ESCUADRADO













9 mm 3/8" 	COLOR	SURFACE	60x120	60x60	30x60
			23 <sup>5/8"</sup> x47 <sup>1/4"</sup>	23 <sup>5/8"</sup> x23 <sup>5/8"</sup>	11 <sup>4/5"</sup> x23 <sup>5/8"</sup>
MATCH-UP 	CINNAMON	COMFORT	772195	772240	772228
		GRIP	772196	-	-

**GRES FINE PORCELLANATO**FINE PORCELAIN STONEWARE / GRÈS CÉRAME FIN / FEINSTEINZEUG-KOLLEKTIONEN / GRES PORCELÁNICO FINO  
SQUADRATO - SQUARED - EQUARRI - REKTIFIZIERT - ESCUADRADO9 mm 3/8" 

COLOR	SURFACE	30x30 11 <sup>4</sup> / <sub>5</sub> "x11 <sup>4</sup> / <sub>5</sub> "  mosaico tessere 3x3
-------	---------	---

0,5x60 1/4"x23 <sup>5</sup> / <sub>8</sub> " <hr/> matita inox
--

719674

	SUGAR	COMFORT	772264
	SUGAR MIX	COMFORT	772271
	COOKIE	COMFORT	772265
	COOKIE MIX	COMFORT	772272
	EARL GREY	COMFORT	772267
	EARL GREY MIX	COMFORT	772274
	COFFEE	COMFORT	772266
	COFFEE MIX	COMFORT	772273
	LIQUORICE	COMFORT	772268
	LIQUORICE MIX	COMFORT	772275
	BLUEBERRY	COMFORT	772270
	CINNAMON	COMFORT	772269











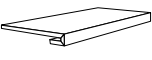



**MATCH-UP**

**In relazione alle differenti tecnologie produttive l'accostamento di prodotti con spessori diversi potrebbe presentare delle disomogeneità, se ne sconsiglia pertanto l'abbinamento.**  
 Due to the different production technologies, contiguous installation of products with different thickness may give a non-homogeneous result. For this reason we do not recommend this option. / Vu que différentes technologies de production sont utilisées avec des épaisseurs différentes, des problèmes d'homogénéité pourraient se présenter, il est donc déconseillé de les poser ensemble. / Wegen unterschiedlicher Produktionstechnologien können die Fliesen mit verschiedenen Materialstärken optische Differenzen aufweisen. Von einem direkten Aneinanderlegen wird deshalb abgeraten. / Dadas las diferentes tecnologías productivas, la combinación de productos de diferentes espesores podría dar lugar a heterogeneidad, por lo que se desaconseja mezclarlas.















**GRES FINE PORCELLANATO**

FINE PORCELAIN STONEWARE / GRÈS CÉRAME FIN / FEINSTEINZEUG-KOLLEKTIONEN / GRES PORCELÁNICO FINO  
SQUADRATO - SQUARED - EQUARRI - REKTIFIZIERT - ESCUADRADO

PEZZI SPECIALI/SPECIAL TRIMS/PIÈCES SPÉCIALES/FORMSTÜCKE/PIEZAS ESPECIALES



9 mm 3/8" ↑↓		COLOR	SURFACE	4,6x60 1 4/5"x23 5/8" 	33x120x3 13"x47 1/4"x1 1/8" 	33x120x3 13"x47 1/4"x1 1/8" 	33x120x3 13"x47 1/4"x1 1/8" 
<b>MATCH-UP</b>		SUGAR	COMFORT	772251	772289	772276	772348
		SUGAR MIX	COMFORT	772258	772296	772283	772355
		COOKIE	COMFORT	772252	772290	772277	772349
		COOKIE MIX	COMFORT	772259	772297	772284	772356
		EARL GREY	COMFORT	772254	772292	772279	772351
		EARL GREY MIX	COMFORT	772261	772299	772287	772358
		COFFEE	COMFORT	772253	772291	772278	772350
		COFFEE MIX	COMFORT	772260	772298	772285	772357
		LIQUORICE	COMFORT	772255	772293	772280	772352
		LIQUORICE MIX	COMFORT	772262	772300	772288	772359
		BLUEBERRY	COMFORT	772257	772295	772282	772354
		CINNAMON	COMFORT	772256	772294	772281	772353



**MATCH-UP**

6 mm 1/4" ↑↓		COLOR	SURFACE	30x30 11 4/5"x11 4/5" 	30x30 11 4/5"x11 4/5" 	6 mm 1/4" ↑↓		COLOR	SURFACE	4,6x60 1 4/5"x23 5/8" 
<b>MATCH-UP</b>		SUGAR	COMFORT	772547	772556	<b>MATCH-UP</b>		SUGAR	COMFORT	772566
		SUGAR MIX	COMFORT	772550	772559			SUGAR MIX	COMFORT	772571
			GLOSSY	772553	772562		GLOSSY		772574	
		COOKIE	COMFORT	772548	772557			COOKIE	COMFORT	772569
		COOKIE MIX	COMFORT	772551	772560			COOKIE MIX	COMFORT	772572
			GLOSSY	772554	772563				GLOSSY	772575
		EARL GREY	COMFORT	772549	772558			EARL GREY	COMFORT	772570
		EARL GREY MIX	COMFORT	772552	772561			EARL GREY MIX	COMFORT	772573
			GLOSSY	772555	772564				GLOSSY	772576

PEZZI SPECIALI/SPECIAL TRIMS/PIÈCES SPÉCIALES/FORMSTÜCKE/PIEZAS ESPECIALES

**GRES PORCELLANATO SMALTATO**GLAZED PORCELAIN STONWARE / GRES CÉRAMÉ ÉMAILLÉ / GLASIERTE FEINSTEINZEUG / GRES PORCELÁNICO ESMALTADO / Глазурованный керамогранит  
SQUADRATO - SQUARED - EQUARRI - REKTIFIZIERT - ESCUADRADO - КАЛИБРОВАННА**60x120**  
23<sup>5/8</sup>"x47<sup>1/4</sup>"**9 mm** 3/8" ↑ ↓**120x280**  
47<sup>1/4</sup>"x110<sup>1/4</sup>"**6 mm** 1/4" ↑ ↓FLORIM OVERSIZE  
**magnUm**

<b>9 mm</b> 3/8" ↑ ↓	COLOR	SURFACE	<b>60x120</b> 23 <sup>5/8</sup> "x47 <sup>1/4</sup> "
	WAVES	NATURALE/MATTE	772831
<b>MATCH-UP</b>			
	TROPICO	NATURALE/MATTE	772835

<b>6 mm</b> 1/4" ↑ ↓	COLOR	SURFACE	<b>120x280</b> 47 <sup>1/4</sup> "x110 <sup>1/4</sup> "
	WAVES	NATURALE/MATTE	772823
<b>MATCH-UP</b>			
	TROPICO	NATURALE/MATTE	772834

Ogni soggetto è caratterizzato da una decorazione che continua da pezzo a pezzo considerando 2mm di fuga. Prima di passare alla fase di posa stendere i vari soggetti a terra per verificare la continuità del prodotto. / Each panel features a pattern that continues from piece to piece with a 2 mm joint. Before laying, spread the various panels on the ground to check the pattern's continuity. / Chaque sujet se caractérise par une décoration qui continue d'une pièce à l'autre, en tenant compte de 2 mm de joint. Avant de passer à la phase de pose, étaler les différents sujets au sol, pour en vérifier la continuité de la décoration. / Jedes Muster ist von einem Dekor charakterisiert, das von Platte zu Platte weiterverläuft, wenn man von der 2 mm Fuge absieht. Sollte vor dem Verlegen die einzelnen Muster auf den Boden angeordnet werden, um die Kontinuität des Dekors zu prüfen. / Cada pieza se caracteriza por una decoración que continúa de una a otra con una fuga de 2 mm. Antes de pasar a la fase de colocación extender los diferentes motivos sobre el suelo para comprobar la continuidad de la decoración.

## DECORO WAVES



## DECORO TROPICO



GRES PORCELLANATO SMALTATO GLAZED PORCELAIN STONEWARE - GRES CÉRAMÉ ÉMAILLÉ - GLASIERTE FEINSTEINZEUG - GRES PORCELÁNICO ESMALTADO		PRESCRIZIONE STANDARD REQUIREMENTS PRESCRIPTIONS / ANFORDERUNGEN PRESCRIPCION		RISULTATI TESTS TEST RESULTS / RESULTATS DES ESSAIS PRUFERGERBNIS / RESULTADOS TESTS	RIFERIMENTO NORMA REFERENCE STANDARD RÉFÉRENCE NORME STANDARDWERT REFERENCIA NORMA
		N ≥ 15 cm		Naturale/Matte	
		(%)	(mm)		
Caratteristiche di qualità secondo i tests di controllo previsti dalle norme EN 14411-ISO 13006 appendice G gruppo B1a GL / Quality characteristics according to the inspection tests envisaged by standard EN 14411-ISO 13006 appendix G group B1a GL / Caractéristiques de qualité selon les tests de contrôle prévus par les normes EN 14411-ISO 13006 appendice G groupe B1a GL / Qualitätseigenschaften gemäß den Kontrolltests der Normen EN 14411-ISO 13006, Anhang G Gruppe B1a GL / Características de calidad según los ensayos previstos por las normas EN 14411-ISO 13006 appendice G grupo B1a GL					
Lunghezza e larghezza (deviazione ammissibile dalla dimensione di fabbricazione) / Length and width (admitted tolerance from factory size) / Longueur et largeur (tolérance admissible de la dimension de fabrication) / Länge und Breite (zulässige Abweichung von den Fabrikationsabmessungen) / Longitud y anchura (desviación admisible respecto al tamaño de fabricación)	Squadrato ISO 13006	±0,3%	±1,0mm	±0,15%	
Spessore: deviazione dello spessore medio di ogni piastrella dalle dimensioni di fabbricazione in % / Thickness: average thickness tolerance, in % versus production dimension / Epaisseur: écart de l'épaisseur moyenne pour chaque carreau par rapport aux dimensions de fabrication en % / Dicke: abweichung der vom hersteller angegebenen stärke in % / Espesor: desviación del espesor medio de cada azulejo respecto a las medidas de fabricación en %	-	±5%	±0,5mm	±5%	
Rettilinearità degli spigoli/Straightness of edges / Rectitude des bords / Geradlinigkeit der Kanten / Rectitud de las aristas	Squadrato ISO 13006	±0,3%	±0,8mm	±0,1%	ISO 10545-2
Ortogonalità in % / Orthogonalité en % / Rechtwinkligkeit in % / Ortogonalidad en %	Squadrato ISO 13006	±0,3%	±1,5mm	±0,2%	
Planarità (curvatura del centro, dello spigolo e svergolamento)/Flatness (curving in the middle, corner and warping) / Planéité (courbure centrale, de l'arête et gauchissement)/Ebenflächigkeit (krümmung der mitte, der kante und verwindung) / Planitud (curvatura del centro, de la arista y abarquillamiento)	Squadrato ISO 13006	±0,4 %	±1,8mm	±0,35%	
Qualità della superficie Surface quality / Qualité de la surface / Oberflächenqualität Calidad de la superficie de acabado	Il 95% min delle piastrelle deve essere esente da difetti visibili. / At least 95% of the tiles must be free from visible flaws. / 95% min des carreaux ne doivent présenter aucun défaut visible. / Mindestens 95% der Fliesen müssen frei von sichtbaren min. / El 95% de las baldosas tiene que estar exento de defectos visibles		CONFORME/CONFORMING CONFORME/KONFORM CONFORME		
Massa d'acqua assorbita in % % Water absorption / Masse d'eau absorbée en % / Wasseraufnahme in % Masa de agua absorbida en %		E≤0,5%		valore medio 0,08%	ISO 10545-3
Forza di rottura in N (spessore ≥ 7,5 mm) / Rupture force in N (thickness ≥ 7,5 mm) / Force de rupture en N (ép. ≥ 7,5 mm) Bruchkraft in N (dicke ≥ 7,5 mm) / Fuerza de rotura en N (gr. ≥ 7,5 mm)		1300 min		valore medio 2200 N spessore 10mm	ISO 10545-4
Forza di rottura in N (spessore < 7,5 mm) - Breaking strength in N (thickness < 7,5 mm) - Force de rupture en N (ép. < 7,5 mm) - Bruchkraft in N (dicke < 7,5 mm) - Fuerza de rotura en N (gr. < 7,5 mm)		≥ 700		valore medio 1350 N spessore 6mm	
Resistenza alla flessione in N/mm2 Bending strength N/mm2 / Résistance à la flexion N/mm2 Biegefestigkeit in N/mm2 / Resistencia a la flexion en N/mm2		35 min		valore medio 50N/mm² spessore 10mm valore medio 52N/mm² spessore 6mm	ISO 10545-4
Resistenza all'abrasione Resistance to abrasion / Résistance à l'abrasion / Abriebfest Resistencia a la abrasión	come dichiarato dal produttore / see manufacturer's declaration / selon déclaration du producteur / entsprechend der herstellangaben / tal como declara el fabricante			Classe 3	ISO 10545-7
Resistenza alle macchie Resistance to staining / Résistance aux taches / Fleckenabweisend Resistencia a las manchas		Classe 3 min		Classe 5	ISO 10545-14
Resistenza agli sbalzi termici / Thermal shocks resistant Résistance aux variations thermiques / Temperaturwechselbeständigkeit Resistencia al choque térmico		-		Resiste - Résistant Resiste - Erfüllt Resiste	ISO 10545-9
Resistenza ai prodotti chimici di uso domestico ed additivi per piscine / Resistance to house and swimming pool chemicals / Résistance aux produits d'emploi domestiques et additifs pour piscines / Widerstand gegen Haushaltschemikalien, Badewasserzusätze / Resistencia a los productos químicos de uso doméstico y aditivos para piscinas		Classe B min		GA	ISO 10545-13
Resistenza a basse concentrazioni di acidi e alcali. / Resistance to low concentrations of acids and alkalis. / Résistance a basses concentrations d'acides et alcalis. / Widerstand gegen niedrige konzentrationen von sauren und laugen. / Resistencia a bajas concentraciones de acidos y alcalis.	come dichiarato dal produttore / see manufacturer's declaration / selon déclaration du producteur / entsprechend der herstellangaben / tal como declara el fabricante			GLA	ISO 10545-13
Resistenza al gelo - frost resistance résistance au gel - frostsicherheit resistencia a la helada		Richiesta / Required / Requisite / Gefordert Requerida		Resiste - Résistant Resiste - Erfüllt Resiste	ISO 10545-12
Coefficiente d'attrito (scivolosità) - friction coefficient (slipperiness) - coefficient de friction (glissement) reibungskoeffizient (schlupfgrigkeit) - coeficiente de anti deslizamiento				>0,42 WET  6° ≤ α < 10°R9	ANSI A 326.3  DIN EN 16165 ANNEX B

## GRES FINE PORCELLANATO

FINE PORCELAIN STONEWARE / GRÈS CÉRAME FIN / FEINSTEINZEUG-KOLLEKTIONEN / GRES PORCELÁNICO FINO  
SQUADRATO - SQUARED - EQUARRI - REKTIFIZIERT - ESCUADRADO

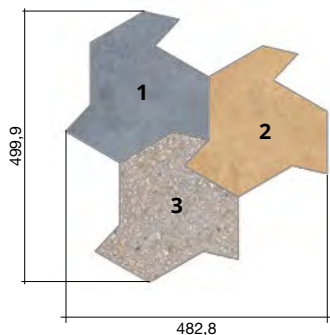

DECORO SHAPES 772836

- 1) BLUEBERRY
- 2) CINNAMON
- 3) EARL GREY MIX



**Il decoro SHAPES è disponibile a magazzino nei colori EARL GREY MIX+CINNAMON+BLUEBERRY** / The SHAPES décor is available in stock in the colours EARL GREY MIX+CINNAMON+BLUEBERRY. / Le décor SHAPES est disponible en stock dans les couleurs EARL GREY MIX+CINNAMON+BLUEBERRY. / Der Dekor SHAPES ist in den Farben EARL GREY MIX+CINNAMON+BLUEBERRY als Lagerware bestellbar. / La decoración SHAPES está disponible en stock en los colores EARL GREY MIX+CINNAMON+BLUEBERRY .

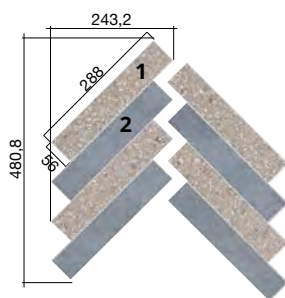

DECORO ZIG ZAG 772838

- 1) EARL GREY MIX
- 2) BLUEBERRY

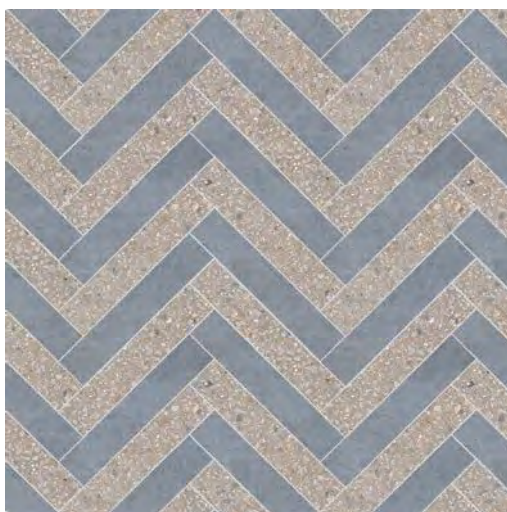

**Il decoro ZIG ZAG è disponibile a magazzino nei colori EARL GREY MIX+BLUEBERRY** / The ZIG ZAG décor is available in stock in the colours EARL GREY MIX+BLUEBERRY. / Le décor ZIG ZAG est disponible en stock dans les couleurs EARL GREY MIX+BLUEBERRY. / Der Dekor ZIG ZAG ist in den Farben EARL GREY MIX+BLUEBERRY als Lagerware bestellbar. / La decoración ZIG ZAG está disponible en stock en los colores EARL GREY MIX+BLUEBERRY .

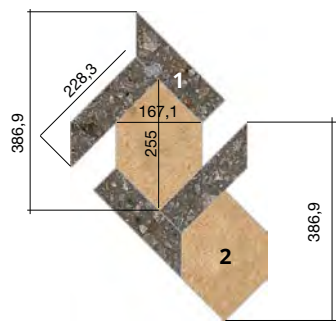
**GRES FINE PORCELLANATO**FINE PORCELAIN STONEWARE / GRÈS CÉRAME FIN / FEINSTEINZEUG-KOLLEKTIONEN / GRES PORCELÁNICO FINO  
SQUADRATO - SQUARED - EQUARRI - REKTIFIZIERT - ESCUADRADO**MATCH-UP**

DECORO LOCK 772840

1) COFFEE MIX

2) CINNAMON



**Il decoro LOCK è disponibile a magazzino nei colori COFFEE MIX+CINNAMON / The LOCK décor is available in stock in the colours COFFEE MIX+CINNAMON. Le décor LOCK est disponible en stock dans les couleurs COFFEE MIX+CINNAMON. / Der Dekor LOCK ist in den Farben COFFEE MIX+CINNAMON als Lagerware bestellbar. / La decoración LOCK está disponible en stock en los colores COFFEE MIX+CINNAMON .**

9 mm 3/8" ↑↓			SURFACE		ON DEMAND*
		DECORO SHAPES	COMFORT	772836	772837
<b>MATCH-UP OF CERIM</b>		DECORO ZIG ZAG	COMFORT	772838	772839
		DECORO LOCK	COMFORT	772840	772841

6 mm 1/4" ↑↓			SURFACE	ON DEMAND*
		DECORO SHAPES	COMFORT	774073
<b>MATCH-UP OF CERIM</b>		DECORO ZIG ZAG	COMFORT	774074
		DECORO LOCK	COMFORT	774049

**\*I restanti colori sono ordinabili su richiesta tramite i codici on demand della tabella, scegliendo colori e finiture nel modo in cui si desidera. / The remaining colours can be ordered on request using the "on demand" codes in the table, specifying the desired colours and finishes. / Les autres couleurs peuvent être commandées sur demande avec les codes spécifiques du tableau en pièce jointe, en indiquant les couleurs et les finitions que l'on souhaite. / Die restlichen Farben können auf Anfrage über die On-Demand-Codes der Tabelle bestellt werden, wobei Farben und Oberflächen nach Ihren Wünschen ausgewählt werden. / El resto de colores se pueden pedir a través de los códigos de la tabla, eligiendo colores y acabados como desee.**

# MATCH-UP OUTDOOR

## Vantaggi tecnici - Technical advantages - Avantages techniques Technische Vorteile - Ventajas técnicas

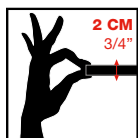

- Lastra monolitica compatta di spessore 2 cm squadrata e rettificata
- Compact monolithic slab 2 cm thick squared and rectified
- Dalle monolithique compacte de 2 cm d'épaisseur, égarrie et rectifiée
- Kompakte monolithische Platte, 2 cm dick, rechteckig und scharfkantig geschliffen
- Losa monolítica compacta de 2 cm de espesor, escuadrada y rectificada.

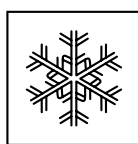

- INGELIVO
- FROST RESISTANT
- INGÉLIF
- FROSTBESTÄNDIG
- RESISTENTE A LA HELADA

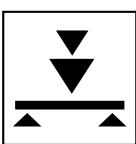

- ELEVATA RESISTENZA AI CARICHI STATICI
- HIGH STATIC LOAD RESISTANCE
- RÉSISTANCE ÉLEVÉE AUX CHARGES STATIQUES
- HOHE STATISCHE BELASTBARKEIT
- ELEVADA RESISTENCIA A LAS CARGAS ESTÁTICAS

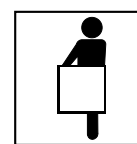

- FACILE DA POSARE
- EASY TO INSTALL
- FACILE À POSER
- VERLEGELEICHT
- FÁCIL DE COLOCAR



- ANTISCIVOLO R11
- ANTI SLIP R11
- ANTIDÉRAPANT R11
- RUTSCHFEST R11
- ANTIDESLIZANTE R11

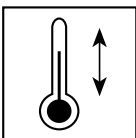

- RESISTENTE AGLI SBALZI TERMICI
- THERMAL SHOCK RESISTANT
- RÉSISTANT AUX ÉCARTS THERMIQUES
- TEMPERATURWECHSELBESTÄNDIG
- RESISTENTE A LAS OSCILACIONES TÉRMICAS



- FACILE DA PULIRE
- EASY TO CLEAN
- FACILE À NETTOYER
- REINIGUNGSLEICHT
- FÁCIL DE LIMPIAR

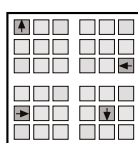

- RIMOVIBILE E RIUTILIZZABILE
- REMOVABLE AND REUSABLE
- DÉMONTABLE ET RÉUTILISABLE
- ENTFERNBAR UND WIEDERVERWENDBAR
- DESMONTABLE Y REUTILIZABLE



- INATTACCABILE DA AGENTI CHIMICI E MUFFE
- IMPERVIOUS TO ATTACK BY CHEMICALS OR MOULD
- RÉSISTANT AUX AGENTS CHIMIQUES ET AUX MOISSISSURES
- UNANGREIFBAR DURCH CHEMISCHE STOFFE UND SCHIMMEL
- RESISTENTE A LOS AGENTES QUÍMICOS Y A LOS MOHOS

## Applicazioni - Applications - Applications - Verlegung - Aplicaciones

- Posa diretta su erba
- Direct installation on grass
- Pose direct sur de l'herbe
- Verlegung direkt auf Rasen
- Colocación directa sobre hierba

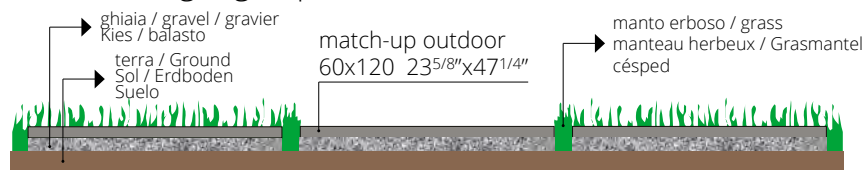

- Posa diretta su ghiaia
- Direct installation over gravel
- Pose direct sur du gravier
- Verlegung direkt auf Kies
- Colocación directa sobre grava



- Posa su massetto cementizio
- Installation on sand-cement screed
- Pose sur chape ciment
- Verlegung auf Zement-Unterbetonblock
- Colocación sobre contrapiso de hormigón

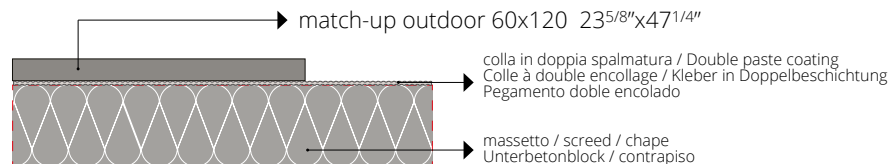

- Posa su piedini fissi o regolabili
- Installation on fixed or adjustable feet
- Pose sur pieds fixes ou réglables
- Verlegung auf feststehende oder regulierbare Füße
- Colocación sobre pies fijos o regulables

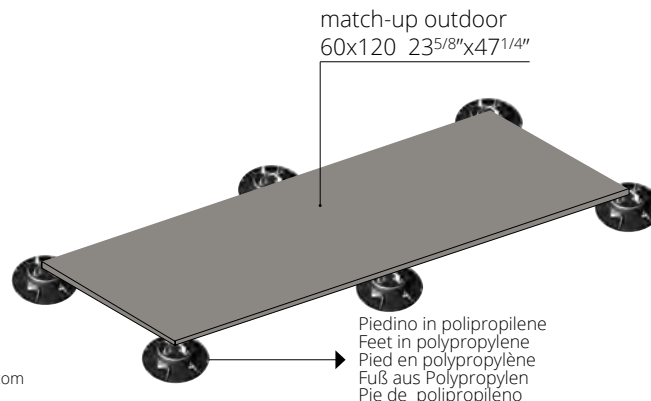

Per le specifiche di utilizzo dei sistemi sopraelevati vedi il sito florim.com  
For the specifics on use of raised systems visit the site florim.com  
Pour les caractéristiques d'utilisation des systèmes surélevés, voir le site florim.com  
Für die Nutzungsbedingungen der Doppelbodensysteme siehe Webseite florim.com  
Para las especificaciones de empleo de los sistemas sobreelevados consulte el sitio web florim.com

Le lastre ceramiche sono sottoposte a un trattamento di compattazione termica che assicura resistenza e durata nel tempo. Il bassissimo assorbimento d'acqua rende perciò il materiale ingelivo. Ciò può comportare ristagni d'acqua superficiali anche per materiale installato a regola d'arte. / Ceramic tiles undergo a compacting thermal treatment that ensures resistance and durability. The low level of water absorption makes the slabs frost resistant. This could result in superficial water stagnations even if materials are installed in a workmanlike manner. / Les carreaux de céramique subissent un traitement thermique de compactage qui assure résistance et durabilité. Le bas niveau d'absorption d'eau rend les dalles résistant au gel. Il pourrait en résulter des stagnations d'eau superficielles, même si les dalles ont été installées dans les règles de l'art. / Die Keramikplatten werden einer thermischen Verdichtung unterzogen, welche die Widerstandsfähigkeit und Langlebigkeit sichert. Die extrem niedrige Wasseraufnahme macht das Material frostsicher. Die hohe Materialdichte kann, auch bei einer perfekten Verlegung, eine längere Abtrochnungszeit von angestaumtem Wasser zur Folge haben. / Las baldosas cerámicas se someten a un tratamiento de compactación térmica que asegura resistencia y durabilidad. La baja absorción de agua hace que las baldosas resistan al hielo. Esto podría resultar en estancamientos superficiales de agua, incluso si los materiales están instalados según las reglas del arte.

## SUGAR



## SUGAR MIX



## COOKIE



## COOKIE MIX



## EARL GREY









## EARL GREY MIX



### GRES FINE PORCELLANATO

FINE PORCELAIN STONEWARE/GRES CERAME FIN/FEINSTEINZEUG-KOLLEKTIONEN/GRES PORCELANICO FINO  
SQUADRATO - SQUARED - EQUARRI - REKTIFIZIERT - ESCUADRADO

20 mm 3/4" ↑	COLOR	SURFACE	60x120 23 <sup>5/8"</sup> x47 <sup>1/4"</sup>
	SUGAR	GRIP	772150
	SUGAR MIX	GRIP	772156
	COOKIE	GRIP	772152
	COOKIE MIX	GRIP	772157
	EARL GREY	GRIP	772155
	EARL GREY MIX	GRIP	772158

### MATCH-UP



SGBP 2018-1992

FLORIM OVERSIZE  
magnUm

<b>CE</b>
<b>FLORIM Ceramiche S.p.A SB</b> Via Canaletto, 24 - 41042 Fiorano Modenese (MO) - Italia 05 <b>FLORIM 001</b> EN 14411:2012 Dry-pressed ceramic tiles, with water absorption $E_b \leq 0,5 \%$ , for internal and external walls and floorings

Per informazioni relative ai dati tecnici su marcatura CE vedere il sito [www.florim.com](http://www.florim.com)  
 Please refer to our web site [www.florim.com](http://www.florim.com) for technical information related to CE labeling  
 Pour tout renseignement sur l'étiquetage CE veuillez consulter le site [www.florim.com](http://www.florim.com)  
 Informationen bezüglich technischer Daten zur Beschriftung CE entnehmen Sie unserer Website [www.florim.com](http://www.florim.com)  
 Para informaciones relativas a las especificaciones técnicas sobre la marca CE, chequear el sitio [www.florim.com](http://www.florim.com)

<b>CE</b>
<b>FLORIM Ceramiche S.p.A SB</b> Via Canaletto, 24 - 41042 Fiorano Modenese (MO) - Italia 09 <b>FLORIM 003</b> EN 14411:2012 Dry-pressed ceramic tiles, with water absorption $E_b \leq 0,5 \%$ , for internal and external walls and floorings

Per informazioni relative ai dati tecnici su marcatura CE vedere il sito [www.florim.com](http://www.florim.com)  
 Please refer to our web site [www.florim.com](http://www.florim.com) for technical information related to CE labeling  
 Pour tout renseignement sur l'étiquetage CE veuillez consulter le site [www.florim.com](http://www.florim.com)  
 Informationen bezüglich technischer Daten zur Beschriftung CE entnehmen Sie unserer Website [www.florim.com](http://www.florim.com)  
 Para informaciones relativas a las especificaciones técnicas sobre la marca CE, chequear el sitio [www.florim.com](http://www.florim.com)



	Sistema di gestione della Qualità: <b>Certificato n°, 50 100 1271</b>
	Sistema di gestione dell'Ambiente: <b>Certificato n°, 50 100 100 74</b>
	Sistema di gestione della Salute e Sicurezza dei lavoratori: <b>Certificato n°, 50 100 13825</b>
	Sistema di gestione dell'Energia: <b>Certificato n°, 50 100 13545</b>



GRADO DI VARIAZIONE CROMATICA - DEGREE OF COLOUR CHANGE - DEGRE DE VARIATION CHROMATIQUE - GRAD DER FARBBABWEICHUNG - GRADO DE VARIACIÓN CROMÁTICA

<p><b>V1 LOW</b> THE LEAST AMOUNT OF SHADE AND TEXTURE VARIATION ATTAINABLE IN NATURALLY FIRED CLAY PRODUCTS.</p> <p>Prodotto Monocromatico Produit Monochromatique Einfarbiges Produkt Producto Monocromático</p>	<p><b>V2 MODERATE</b> LIGHT TO MODERATE SHADE AND TEXTURE VARIATION WITHIN EACH CARTON.</p> <p>Prodotto con leggera variazione cromatica Produit à légère variation chromatique Produkt mit leichter Farbnuance Producto con una pequeña variación cromática</p>	<p><b>V3 HIGH</b> HIGH SHADE AND TEXTURE VARIATION WITHIN EACH CARTON.</p> <p>Prodotto con marcata variazione cromatica Produit à variation chromatique accentuée Produkt mit ausgeprägter Farbnuance Producto con evidente variación cromática</p>	<p><b>V4 RANDOM</b> VERY HIGH SHADE AND TEXTURE VARIATION WITHIN EACH CARTON.</p> <p>Prodotto con forte variazione cromatica Produit à forte variation chromatique Produkt mit starker Farbnuance Producto con fuerte variación cromática</p>
CEMENTO	MIX		

Quanto contenuto nel catalogo è indicativo e non esaustivo riguardo alle grafiche, decori e ai colori riportati./Contents of this catalog is indicative and not exhaustive with regard to graphics, decors and colors shown. /Le contenu du catalogue est indicatif et non exhaustif en ce qui concerne graphiques, décors et couleurs indiquées. /Die Beschreibungen im Katalog sind indikativ und nicht allumfassend in Bezug auf Grafiken, Dekore und Farben. /El contenido de este catálogo es indicativo y no exhaustivo con respecto a gráficas, decoros y colores ilustrados.





**FLORIM**



**Florim Ceramiche S.p.A. SB**

Via Canaletto, 24 /41042 Fiorano Modenese (MO) / T. +39 0536 840111 / F. +39 0536 844750 / [florim.com](http://florim.com)